VMECC Specification

Ron Kolb

Revision 0.97

|

Table of Contents

CHAPTER 1	Introduction	7
	1.1 Purpose	7
	1.2 Features	7
CHAPTER 2	Software Specification.	9
	2.1 VME PIO Addressing	9
	2.1.1 Little Windows and Big Windows	9
	2.1.2 RMW operation	13
	2.2 VME Slave Addressing	13
	2.2.1 A24, A32, and A64 Enable Bits	13
	2.2.2 A64 Upper Match Register	14
	2.3 Interrupts	14
	2.3.1 VME levels	14
	2.3.2 Auxiliary Interrupt inputs	15
	2.3.3 DMA Engine Interrupts	15
	2.3.4 Error Interrupts	15
	2.3.5 General Interrupt Issues	15
	2.3.6 Interrupt Hardware Details	16
	2.4 Coherence Issues	19
	2.5 Local Register Description and Address Map	20
	2.5.1 RMW Group and Loopback	20
	2.5.2 Error Group	21
	2.5.3 DMA Engine	24
	2.5.4 Configuration Group	25
	2.5.5 Interrupts, IACK Values, and General Purpose I/O	27
	2.5.6 PIO Mapping and PIO Timer	31
	2.6 Diagnostics Features	33
	2.7 Error Handling	33
	2.8 Bi-Endian Support	33
	2.9 Device ID	34

CHAPTER 3	Hardware Specification.....	35
3.1	Block diagram	35
3.1.1	FCI Input Block	37
3.1.1.1	Input Synchronizer	37
3.1.1.2	PIO Address Fifo	37
3.1.1.3	PIO Data Fifo	37
3.1.2	FCI Output Block	37
3.1.2.1	Interrupt Vectors	37
3.1.2.2	DMA Write Fifo	37
3.1.2.3	Read Responses	37
3.1.3	Local Registers	37
3.1.4	VME Bus Multiplexers and Registers	37
3.1.5	Slave Decoder	37
3.1.6	VME Arbiter	37
3.1.7	Interrupt Handler	37
3.2	FCI Interface	37
3.3	VME Interface	37
CHAPTER 4	Testability.....	39
4.1	Diagnostics	39
4.2	Scan	39
CHAPTER 5	Implementation.....	41
5.1	Technology	41
5.2	Gate Count	41
5.3	Package Type	41
5.4	Pin List	42
5.4.1	FCI Side	42
5.4.2	VME Side	43
5.4.3	Pin Count Summary	46
CHAPTER 6	External Buffer Parts	67

List of Tables

Table 1:	PIO Big Window Mapping	11
Table 2:	Internal Register Summary	12
Table 3:	RMW Group	21
Table 4:	DMA Engine Group	24
Table 5:	Configuration Group	27
Table 6:	Interrupt Vector Group	28
Table 7:	Interrupt Mask Group	29
Table 8:	PIO Mapping and Timer Group	32
Table 9:	Device ID	34
Table 10:	FCI Side Pins	42
Table 11:	VME Side Pins	43
Table 12:	Total Pins	46
Table 13:	Chip Pinout by Name	47
Table 14:	Chip Pinout by Pin Number	57
Table 15:	External Buffer Parts Required	68

List of Figures

Figure 1	Interrupt State Machine Concept	18
Figure 2	VMECC Block Diagram	36

1.1 Purpose

The VMECC provides an interface to a VME bus for the Everest system. It is connected to an F-chip on an IO4 or similar board by a 60 signal flat cable. The cable arrangement, even when constrained to be in the same cabinet as the IO4 board and limited to five feet of cable, gives much more flexibility to the placement of the VME bus and allows multiple buses to exist.

1.2 Features

The VMECC features include:

- A16, A24, A32, A64 addressing modes can be issued as bus master with PIOs.
- Single item transfers (D8, D16, D32, and D64) can be issued as bus master with PIOs.
- A24, A32, A64 addressing modes can be responded to as a memory slave providing access to the EBUS; A24 and A32 access is mapped on a page basis; A64 access is direct (unmapped) to EBUS addresses.

- Single item transfers (D8, D16, D32), Block Transfer (D8, D16, and D32), and Multiplexed Transfer (D64) can be responded to as a memory slave providing access to the EBUS.
- The VMECC includes an internal DMA engine to speed copies between EBUS memory and VME space. The addressing mode bits, VME address, datum size, block/non-block, a bus throttle value, direction, and transfer size are all programmable. The VME address is a single incrementing range of addresses; the EBUS address is likewise a single incrementing range, but because it is mapped, the physical EBUS address can scatter/gather on a page basis.
- The VMECC has a 16-deep PIO fifo to smooth writing to the VME bus from R4000s.
- The VMECC has an explicit internal delay register to aid in spacing PIOs for boards that require such a kludge.
- The VMECC has provision for Test and Set operations for D8, D16, D32 with A16, A24, and A32 on the VME bus using a VME bus Read Modify Write cycle.
- The VMECC has a built-in VME interrupt handler. It will be possible for an external agent to handle some of the interrupt levels.
- The VMECC has a built-in VME bus arbiter.
- VME “slot 0” functions such as bus timer, iack driver, clock driver, etc. are supported in the VMECC.
- The VMECC has two general purpose input pins that can cause EBUS interrupts and two general purpose output pins.

CHAPTER 2

Software Specification

2.1 VME PIO Addressing

2.1.1 Little Windows and Big Windows

Each IOA (the F-chip in this case) on the I-bus has 64KB of little window EBUS address space that can be accessed without TLB entries and 128MB of big window address space that does require TLBs. The F-chip combines the two spaces into one 128MB piece (the first 64KB of the big window accesses the same locations as the little window) and takes the first 4KB for its own internal registers. The rest (128MB minus 4KB) is passed to the VMECC.

The VMECC divides the 128MB into 16 8MB pieces. The first 8MB piece is for internal registers and A16 space. The VMECC has a 15 entry mapping ram for pieces 1-15. Each 8MB piece is expanded to 32 bits of address with 9 bits from the ram and given a 6 bit AM field. There is a single 32 bit register to provide the additional bits for A64. It is shared by both PIOs and the DMA engine.

PIO reads and writes of double word (8byte) size to the VME bus have the lower two AM bits forced to 0b00 (D64) to conserve mapping entries. If this were not done, two entries would be needed for a given address extension, one with the AM bits set to Axx/D64 and one with the AM bits set to Axx with some other pattern in the two least significant bits.

Table 1: PIO Big Window Mapping

Address Range		Used For
0000000	0000FFF	F-chip addresses (VMECC won't see this range)
0001000	0001FFF	VMECC internal registers
0002000	0003FFF	RMW trigger
0004000	0007FFF	A16 SP (AM=2D) addresses 0000 - 3FFF
0008000	000BFFF	A16 NP (AM=29) addresses 8000 - BFFF
000C000	000FFFF	A16 SP (AM=2D) addresses 8000 - BFFF
0010000	001FFFF	A16 NP (AM=29) addresses 0000 - FFFF
0020000	002FFFF	A16 SP (AM=2D) addresses 0000 - FFFF
0030000	07FFFFFF	reserved (actually aliases for previous addresses)
0800000	0FFFFFFF	mapper entry #1
1000000	17FFFFFF	mapper entry #2
1800000	1FFFFFFF	mapper entry #3
2000000	27FFFFFF	mapper entry #4
2800000	2FFFFFFF	mapper entry #5
3000000	37FFFFFF	mapper entry #6
3800000	3FFFFFFF	mapper entry #7
4000000	47FFFFFF	mapper entry #8
4800000	4FFFFFFF	mapper entry #9
5000000	57FFFFFF	mapper entry #10
5800000	5FFFFFFF	mapper entry #11
6000000	67FFFFFF	mapper entry #12
6800000	6FFFFFFF	mapper entry #13
7000000	77FFFFFF	mapper entry #14
7800000	7FFFFFFF	mapper entry #15

Table 2: Internal Register Summary

Register Name	Address
CONFIG	1000
A64SLVMATCH	1008
A64MASTER	1010
ERRADDRVME	1018
RMWMASK	1080
RMWSET	1088
RMWADDR	1090
RMWAM	1098
DMAVADDR	1100
DMAEADDR	1108
DMABCNT	1110
DMAPARMS	1118
PIOTIMER	1180
LOOPBACKTRIG	11C0
INT_ENABLE	1200
INT_REQUESTSM	1208
INT_REQUESTRAW	1210
ERRCAUSES	1218
INT_ENABLECLR	1220
ERRCAUSESCLR	1238
INT_ENABLESET	1240
ERRXTRAVME	1280
IACK	1288-12B8
VECTORS	1300-1350
PIOMAP	1380-13F8
RMWTRIG	2000-2007

2.1.2 RMW operation

There are five registers associated with performing the Test and Set operation on the VME bus with a RMW operation. One 32 bit register is the address and another 6 bit register is for the AM bits. Only A16, A24 and A32 addresses can be used (no A64) and D64 is not supported. Two more 32 bit registers provide a mask and a set value. All of these registers must be written before initiating the operation with a read to the trigger location. The size of the operation (byte, half-word, word) is determined by the size of the read at the trigger location. Once the RMW logic has the VME bus, it performs a VME read of the requested data size with the address and AM bits specified. This is the data that is returned from the trigger read over the FCI. However, before any other PIOs in the fifo can be started, a copy of the read data is ANDed with the mask value and ORed with the set value. It is written back to the same VME location that was read. The VME AS signal remains asserted during both the VME read and write operations. Once the VME write finishes, the VMECC may proceed with any further PIOs in its fifo. Since there are five distinct registers to be written and read, software must protect access to them with a software lock. To simplify the hardware, the values in the AND and OR registers must be duplicated in all four bytes for byte operations and duplicated in both half-word locations for half-word operations.

While the RMWAM register can be written to any value (and that value will be returned by a read to its address), the AM pattern which is actually placed on the VME bus will have the two least significant bits set to 0b01 (data). For the anticipated use of this set and set mechanism, neither program, block, or D64-block AM codes make sense.

The RMWTRIG address used must match the value in the RMWADDR location in the three least significant bits. For example, if the value in the RMWADDR register is 0x1234567B, the RMWTRIG trigger read should be from address 0x2005.

2.2 VME Slave Addressing

2.2.1 A24, A32, and A64 Enable Bits

There is a configuration register to enable and disable sections of A24, A32, and A64 address space being recognized as valid slave addresses. The IO2/IO3 recognized all A24 NP or Block accesses with bit A23

equal to zero, and, as usually configured, all A32 NP and Block accesses with the A31-A28 equal to 1000B or 0000B. This behavior can be imitated in the Everest system, although a better partitioning is suggested. An option bit allows access to SP as well as NP address modifiers.

On Everest, A24 will be divided into four sections decoded from the A23 and A22 bits, and A32 will be divided into 16 sections decoded from the A31 to A28 bits. All A32 and A24 accesses must be mapped. The 2048 static ram entries will be indexed by A31-A21, and A20-A12 are the table index bits within the EBUS memory tables. Which 2048 of the 8192 static ram entries connected to the IA/ID chips will be used is set by two bits in the CONFIG register. For A24 access, the static ram addressing bits A31-A24 will be forced to ones. If the enable matching 1111B for A31-A28 of the A32 enables is turned on, then a part of that part of A32 space's mapping entries will be also used by the A24 enables (like the IO2/3).

The IO2/IO3 A24 enable pattern of 00B/01B turned on and 10B/11B turned off can be programmed, but for co-existence with the possibility of another CPU and local memory on the VME bus, it might be better to have 01B/10B turned on and 00B/11B turned off. This allows the bottom and top of the address space for local VME memory. Similarly, for A32, turning on 1000B to 1110B with 1111B turned off might be better.

There is a single bit in the CONFIG register to enable or disable A64 slave operations.

2.2.2 A64 Upper Match Register

The VMECC is capable of responding to one $2^{*}40$ bit section of A64 space. There is a configuration register to set the pattern of A63-A40 to match to respond to A64 addresses as a slave.

2.3 Interrupts

2.3.1 VME levels

The seven VME levels have an EBUS interrupt vector each. These can be reprogrammed by PIO writes at any time and any interrupts occurring as the switch over happens are guaranteed to have either the old or new values.

The VMECC has a mask register with a bit for each of the seven VME levels. If a VME interrupt level is asserted and the mask bit is enabled, the built-in interrupt handler will request the VME bus and do the IACK cycle automatically. The eight bit VME IACK vector value will be stored in a register file location associated with its IRQ level. The mask bit is automatically turned to the disabled state, so that further IACKs and interrupts from that level won't happen until the level is turned on by a PIO write from an R4000. This prevents a continuous series of IACKs for boards that don't remove the IRQ when the IACK happens and also preserves the IACK vector from being overwritten before examination by the R4000.

The mask register bits can be read, cleared with a bit mask, and set with a bit mask for easier manipulation by the R4000s.

2.3.2 Auxiliary Interrupt inputs

There are two pins on the VMECC that cause interrupts back to the EBUS when they are asserted. They have two additional EBUS interrupt vector values and two additional mask bits similar to the seven VME level bits. They are active high levels and cause an interrupt on the leading edge; anything fancier can be handled by a PAL on the VCAM.

2.3.3 DMA Engine Interrupts

There is an EBUS interrupt vector register for the DMA engine's use. It, too, has a mask bit.

2.3.4 Error Interrupts

VMECC detected errors such as Flat Cable Interface protocol errors, VME bus timeouts, etc., share a single EBUS interrupt vector. The conditions have sticky bits in an error register, but the same CPU or CPU group is interrupted for all.

2.3.5 General Interrupt Issues

All of the EBUS interrupt vectors must be unique because the VMECC does not have a parallel set of settable and clearable bits which would duplicate the function of the 128 level bits in the CCs. If two VMECC levels were to operate on the same one of the 128 CC levels, a CPU would

have no way to know, for instance, which of the VME IACK RAM locations to look at.

Unlike the MPBUS systems, it is not anticipated that VME interrupt enable bits will be cleared by software in normal operation; they must be set to re-enable interrupts after the auto-clear caused by sending an EBUS interrupt request and they may be cleared permanently to allow another CPU on the VME bus to handle certain VME interrupt levels. If a CPU did clear the interrupt enable bit, interrupts could occur for a basically indeterminate amount of time after issuing the clear. There is no status available to guarantee that an “in-flight” interrupt has reached the target CC.

2.3.6 Interrupt Hardware Details

The seven VME interrupt lines are synchronized and *ANDed* with the appropriate INTENABLE bits. Whenever any of these seven terms is set, the VME interrupt handler makes a request to gain control of the VME bus to the VME BUS ARBITER. When it gets control, it issues an IACKOUT and performs an IACK read to the highest priority (1 highest; 7 lowest) VME level. This causes:

- the resulting 8 bit IACK vector to be written into the appropriate IACKVMEx register
- the corresponding *x* bit in the INTENABLE register to be automatically reset
- the corresponding *x* bit in the INTREQUESTSM register to be set

The INTREQUESTSM register can also have bits set by diagnostics software. Whenever any of its bits are set, another state machine will schedule sending interrupt vectors obtained from the VECTORxxx registers over the FCI bus. It will wait for appropriate conditions such as DMA Write Buffer Flushing, etc. This set of state machine bits has four additional bits beyond the seven VME interrupt levels for the DMA engine, the two auxiliary interrupt inputs, and the error register. For all levels, as the interrupt order is sent over the FCI, the corresponding INTREQUESTSM state machine bit is reset.

The seven VME interrupt levels have their INTENABLE bit reset when an interrupt occurs because there is a need to preserve the contents of the IACKVMEx register until software can read it. After software reads the IACKVMEx register, it should write to set the *xth* bit of the INTENABLE register. A second reason for this auto-reset of an enable bit is that

the VME interrupt levels are level-sensitive (as opposed to edge-triggered). Without the auto-reset, the interrupt handlers might continuously generate VME interrupts if the controller board doesn't remove its IRQ line assertion automatically when it returns the IACK vector. The two auxiliary interrupt pins are not so protected but cause an interrupt only on their leading edge.

The DMA engine and error interrupt INTENABLE bits do not auto-reset; they usually would always be enabled. By its nature, the DMA engine interrupt occurs as the byte count goes to zero (or there's some kind of error) and, since it won't start without some software programming, there is no chance of continuously generating interrupts. The error register case is special. The strategy is that:

- as the number of error bits turned on in ERRCAUSES goes from zero to one or more, an interrupt is sent (the bit in the INTREQUESTSM is set)
- more conditions can occur before an ERRCAUSECLR read is issued (which auto-clears any bits read as ones), but these additional bits don't cause additional interrupts to be sent nor are the bits individually logged. Instead, they cause an overrun bit to be set.

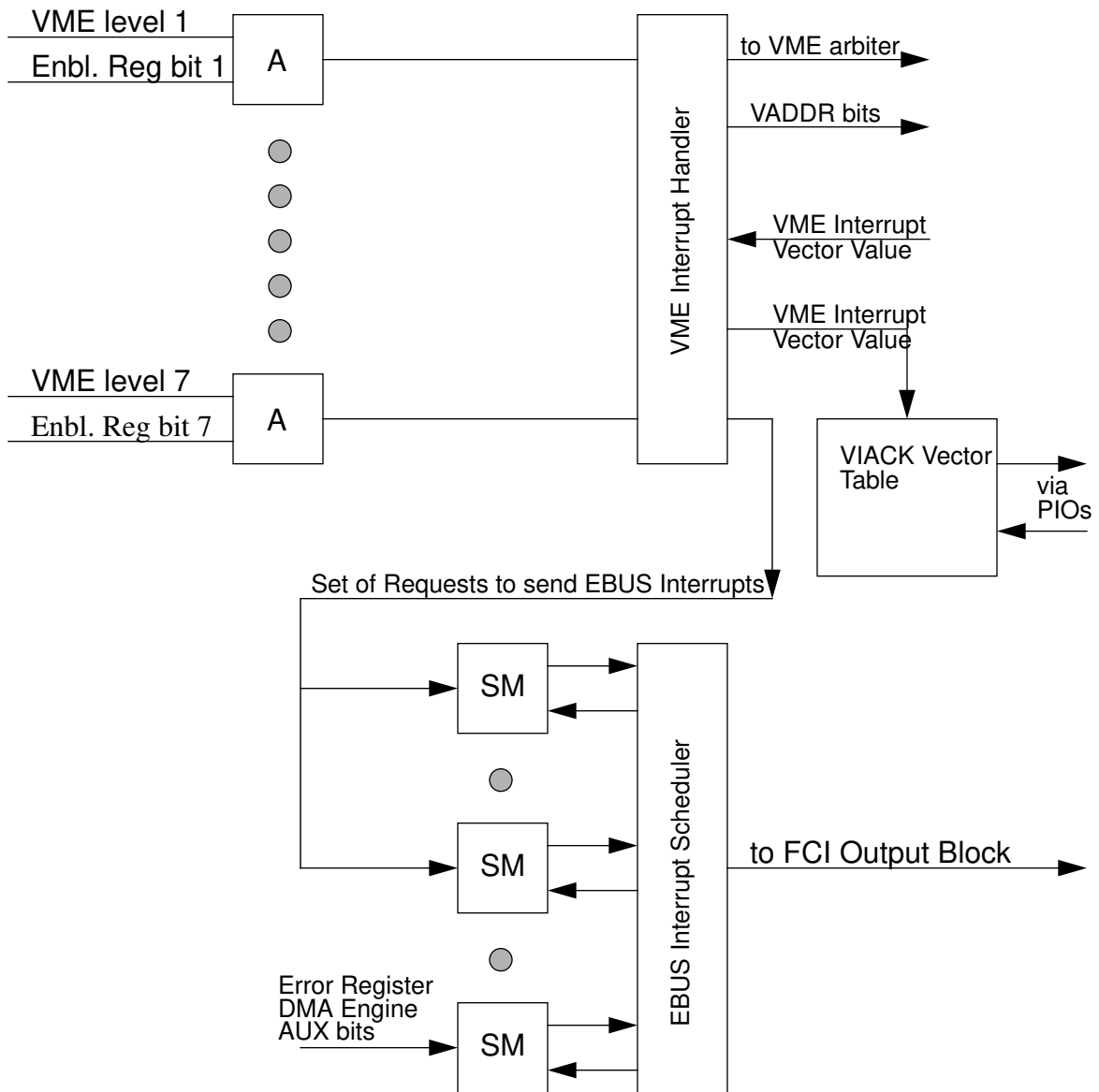

Figure 1

Interrupt State Machine Concept

2.4 Coherence Issues

One of the features of the VMECC is that it will attempt to coalesce VME bus operations that are in the same direction, at adjacent sequential address, with the same datum size, with the same AM bits, and without intervening interrupts. This coalescing in the VMECC is in addition to the coalescing that the F-chip attempts to do with write data sent to it. A timer, with a period on the order of 5 usec, will also break this coalescing. This feature will allow non-block mode devices to access sequential addresses without quite as much overhead as would be required to re-fetch or store every access over the FCI and through the IBUS to the EBUS. It will also help smooth even block mode devices as they must release AS at every 256 byte boundary. Obviously, this requires a “last address plus datum size” register that is compared to new requests.

Pre-fetching of DMA read data can occur if it is properly discarded when a stream is broken. Because pre-fetching to the next page can occur, the map entry beyond the address range actually expected to be used must be initialized and allocated to the current request.

One problem that can arise is that the VME master can switch direction from write to read in a given block of data and quite reasonably expects the new values to appear. The write-back of the data must happen before the read request is issued in the VME chip and the F-chip must similarly be aware of this case and make sure that at least the IA sees the write before issuing the read.

Another subtler issue that cannot be handled in the VMECC is that of multiple virtual aliases for a given piece of memory. That is, since all A24 and A32 accesses are mapped, very different VME addresses could refer to the same physical address. The F-chip, since it knows physical addresses, could handle this and make sure that a read sees the effect of a previous write.

All PIOs, both to internal and VME destinations, are handled strictly in order. Pending DMA writes must be flushed onto the FCI before interrupts are posted. The F-chip must preserve that order. As mentioned elsewhere, re-targeting interrupt levels must result in either the old or new CPU getting the interrupt.

2.5 Local Register Description and Address Map

The software accessible registers within the VMECC will be described in terms of a number of groups of related registers.

Note that the addresses for the internal registers are appropriate for double word (64 bit) access even though the registers are really only a word (32 bits) or less wide. If accessed as double words, code accessing these registers would be endian insensitive. If it is desired that the registers be accessed with word loads and stores instead, the addresses will have to be modified by adding 4 (bytes) to the addresses in big endian mode; the addresses are correct in little endian. There are no byte enables within words, so one cannot, e.g., write only a byte of a word-wide register and a register that happens to really only be a half-word or byte wide would need to have the address listed in this document adjusted by 6 or 7 (bytes) in big endian mode to position the data into the correct byte lane.

2.5.1 RMW Group and Loopback

The RMW operation is a Test and Set type operation and requires a number of registers. The Mask used for the AND function and the Set value used for the OR function are word wide registers. The 6 bit AM register and 32 bit address register are required because the trigger location is a fixed internal address that is read to start the RMW operation. The size of the PIO read operation (byte, half-word, or word only) to the RMWTRIG location is used as the size of the operation on the VME side. Note that A64 and D64 operations are not supported; do not program the RMWAM register to an A64 code. The two least significant AM bits that go out on the VME bus are forced to 0b01 (data). Note also that the three least significant bits of the RMWADDR value and the three least significant bits of the address used for the RMWTRIG access must match for correct operation. Finally, note that the patterns in RMWMASK and RMWSET registers should be repeated twice for half-word operations and repeated in all four byte lanes of the two registers for byte operations.

The FCI loopback trigger uses the low byte of the RWM register for data to check the AUXCMD bits of the FCI.

Table 3: RMW Group

Address	Register Name	Bits	R/W	Function
0001080	RMWMASK	31:0	R/W	<i>AND</i> -function for RMW operation
0001088	RMWSET	31:0	R/W	<i>OR</i> -function for RMW operation
0001090	RMWADDR	31:0	R/W	Address Bits for RMW operation
0001098	RMWAM	5:0	R/W	AM bits for RMW operation
0002000- 0002007 (3 lsb must match RM WADDR)	RMWTRIG	Var.	R	A read from this location triggers RMW operation and returns the contents of AM:ADDR with the operation size obtained from the size of read to this location
00011C0	LOOPBACKTRIG	NA	W	A write to this location initiates an FCI loop-back test with bits 7:0 of the RMWMASK register used as data

2.5.2 Error Group

One register holds the general error cause bits. At one address, it can be read without changing the error bit(s); at another, the error bits that are set in the read data are automatically cleared. Another two registers hold the last VME address along with AM bits, IACK, WRITE, LWORD, DS0, DS1, AS and grant level values along with bits indicating the validity of the two registers.

The first register is the ERRCAUSES register which has a lockout bit that prevents more than one of bits 0, 1, 3, 4, or 5 being set; instead, an error condition different from the first condition to set a bit will cause bit 6, the overrun bit, to be set. Bit 2 (VME slave buserror) does not set the lockout bit and bit 7 (dropmode) is just a “live” status bit.

The ERRXTRAVME register is triggered just before a VME bus timeout asserts BERR. This register does not capture data when a slave asserts BERR, only BERR caused by the bus timer. The ERRADDRVME register is loaded for the addresses the VMECC drives as master and the starting address of slave operations the VMECC handles. When bit 16 of the ERRXTRAVME register (which is the validity bit and also the lockout

bit) sets, bit 15 captures the information that the VMECC is either the master or slave for this operation which indicates whether the ERRAD-DRVME register's contents apply to this timeout.

The one vector associated with the errors are described in the vector group.

Address	Register Name	Bits	R/W	Function
0001018	ERRADDRVME	31:0	R	Last VME address (if known), bit 0 is ~LWD
0001280	ERRXTRAVME	5:0	R	Last VME AM bits
		6	R	Last VME IACK bit
		7	R	Last VME Write bit
		11:8	R	Last VME AS:DS1:DS0:LWORD
		14:12	R	Last VME Grant Level (6:Interrupt Master; 5:PIO Master; 4: DMA Engine; 3-0 VME backplane levels)
		15	R	ERRADDRVME is valid
		16	R/W	ERRXTRAVME is valid (cleared and re-armed by writing to this address -- 1280)
0001218	ERRCAUSES	0	R	VME Buserror on PIO Write (interrupts)
		1	R	VME Buserror on PIO Read (no interrupt but read return has parity error)
		2	R	VME Slave Got Parity Error (no interrupt)
		3	R	VME Acquisition Timeout by PIO Master (interrupts and sets drop mode)
		4	R	FCIDB Timeout (no interrupt)
		5	R	FCI PIO Parity Error (interrupts)
		6	R	Overrun Bit (while one of bits 0-1-3-4-5 is set, a different one of bits 0-1-3-4-5 is requested)
		7	R	Dropmode is set
		11:8	R	Reserved
		15:12	R	Chip Revision. Currently 0x0.
0001238	ERRCAUSECLR	7-0	R-C	Same bits as ERRCAUSES with auto-clear

2.5.3 DMA Engine

The DMA engine has a 32 bit EBUS memory address register (DMAE-ADDR). The address is always virtual (mapped). The engine has a VME address and AM bits register, the DMAVADDR register. The length of the operation is contained in the DMABCNT register. The DMAMODE register has the direction, size of VME bus operation, block/non-block operation, VME AM bits, VME bus throttle value, VME bus request level, and DMA start bit in it. The DMA engine busy bit is set when the DMAMODE location is written with the start bit set and cleared when either the transfer has finished or there is an error. The EBUS interrupt vector associated with it is described in the vector group.

Table 4: DMA Engine Group

Address	Register Name	Bits	R/W	Function
0001100	DMAVADDR	31:0	R/W	DMA engine VME address
0001108	DMAEADDR	31:0	R/W	DMA engine EBUS address
0001110	DMABCNT	23:0	R/W	DMA engine transfer byte count
0001118	DMAPARMS	5:0	R/W	DMA engine AM bits for DMAVADDR
		6	R/W	DMA engine should use block/non-block VME transfers
		8:7	R/W	DMA engine's VME transfers datum size is: 00-byte, 01-hw, 10-wd, 11-64bit
		9	R/W	DMA engine transfers: 0-VME to EBUS; 1- EBUS to VME
		10	R/W	DMA VME side is RWD/ROR (at throttle value)
		11	R/W	DMA throttle value is 2048/256 bytes
		29	R/C	DMA engine got a FCI parity error; cleared by setting bit 31
		30	R/C	DMA engine got a VME buserror; cleared by setting bit 31
		31	R/W	DMA engine is active (set to start xfer)

When a DMA engine interrupt occurs, software should read the DMAPARMS register to see whether the completion was normal or whether

the operation ended because of a VME bus error or a flat cable parity error.

Like double word PIOs, the DMA engine AM is automatically set to D64 when the size is double word.

2.5.4 Configuration Group

The registers in this group are likely to have the same values for all standard systems and certainly only be written at initialization. The parameters are configurable primarily to allow for customer specials. One 32 bit register provides an additional 32 address bits for A64 master operation. A 24 bit register must have its value match A64 address bits A63-40 to allow slave access to EBUS memory. A general configuration register has a variety of configuration bits including which parts of A24 and A32 space and whether A64 space will be enabled for slave access. The other bits are described in the table..

Table 5: Configuration Group

Address	Register Name	Bits	R/W	Function
0001000	CONFIG	0	R/W	VME reset asserted when this bit a 0.
		1	R/W	PIO master doesn't hold its bus grant for about 5 usec before releasing it even if no VME PIOs are immediately available
		2	R/W	DMA engine is VME request level 2.5 (between 3 and 2-1-0) instead of 4 (above 3)
		4:3	R/W	Upper bits of Virtual Address on FCI
		5	R/W	VME slaves will respond to Privileged AM patterns
		6	R/W	Disable VME slave operation coalescing
		7	R/W	FCI Command Overlap Enable
		8	R/W	VME Bus Timeout value is 640 usec/80 usec
		9	R/W	Shorten VME bus timeout and PIO VME bus acquisition access timeout (for diagnostics only)
		10	R/W	Reserved
		11	R/W	Enable A64 slave operations
		15:12	R/W	Each bit is a slave enable for 1/4th of A24
		31:16	R/W	Each bit is a slave enable for 1/16th of A32
0001008	A64SLVMATCH	31:8	R/W	A64 Slave Match Address (VMEA63-40)
0001010	A64MASTER	31:0	R/W	A64 PIO Master/DMA Engine upper 32 bits

2.5.5 Interrupts, IACK Values, and General Purpose I/O

This group contains all of the EBUS interrupt vectors in the VMECC, the corresponding interrupt mask bits, the 7 VME IACK values associated with the 7 VME IRQ levels, and a two general I/O bits for attached processor use. There are four EBUS interrupt vectors in addition to the 7 VME IRQ levels. One is used to signal general VMECC errors, both on the FCI and on the VME bus. Another signals the end of a DMA engine operation. Two general input pins cause interrupts when asserted (high

true levels). They can be used for the generic external interrupt lines often requested or associated with an attached processor. Two general purpose output pins are part of the interrupt mask register and can be set and cleared with the mask clear and mask set operations but do not actually sense or cause interrupts

Table 6: Interrupt Vector Group

Address	Register Name	Bits	R/W	Function
0001300	VECTORERROR	15:0	R/W	Interrupt Vector for VMECC errors
0001308	VECTORVME1	15:0	R/W	Interrupt Vector for VME level 1
0001310	VECTORVME2	15:0	R/W	Interrupt Vector for VME level 2
0001318	VECTORVME3	15:0	R/W	Interrupt Vector for VME level 3
0001320	VECTORVME4	15:0	R/W	Interrupt Vector for VME level 4
0001328	VECTORVME5	15:0	R/W	Interrupt Vector for VME level 5
0001330	VECTORVME6	15:0	R/W	Interrupt Vector for VME level 6
0001338	VECTORVME7	15:0	R/W	Interrupt Vector for VME level 7
0001340	VECTORDMAEN	15:0	R/W	Interrupt Vector for DMA Engine
0001348	VECTORAUX0	15:0	R/W	Interrupt Vector for general purpose intr. 0
0001350	VECTORAUX1	15:0	R/W	Interrupt Vector for general purpose intr. 1
0001288	IACK1	7:0	R/W	VME IACK vector for VME level 1
0001290	IACK2	7:0	R/W	VME IACK vector for VME level 2
0001298	IACK3	7:0	R/W	VME IACK vector for VME level 3
00012A0	IACK4	7:0	R/W	VME IACK vector for VME level 4
00012A8	IACK5	7:0	R/W	VME IACK vector for VME level 5
00012B0	IACK6	7:0	R/W	VME IACK vector for VME level 6
00012B8	IACK7	7:0	R/W	VME IACK vector for VME level 7

Table 7: Interrupt Mask Group

Address	Register Name	Bits	R/W	Function
0001200	INT_ENABLE	0	R/W	Enable bit for VMECC errors
		1	R/W	Enable bit for VME IRQ level 1
		2	R/W	Enable bit for VME IRQ level 2
		3	R/W	Enable bit for VME IRQ level 3
		4	R/W	Enable bit for VME IRQ level 4
		5	R/W	Enable bit for VME IRQ level 5
		6	R/W	Enable bit for VME IRQ level 6
		7	R/W	Enable bit for VME IRQ level 7
		8	R/W	Enable bit for DMA engine
		9	R/W	Enable bit for general purpose input 0
		10	R/W	Enable bit for general purpose input 1
		11	R/W	General purpose output bit 0
		12	R/W	General purpose output bit 1
0001208	INT_REQUESTSM	0	R/W	Interrupt Request for VMECC errors
		1	R/W	Interrupt Request for VME IRQ level 1
		2	R/W	Interrupt Request for VME IRQ level 2
		3	R/W	Interrupt Request for VME IRQ level 3
		4	R/W	Interrupt Request for VME IRQ level 4
		5	R/W	Interrupt Request for VME IRQ level 5
		6	R/W	Interrupt Request for VME IRQ level 6
		7	R/W	Interrupt Request for VME IRQ level 7
		8	R/W	Interrupt Request for DMA engine
		9	R/W	Interrupt Request for general purpose input 0
		10	R/W	Interrupt Request for general purpose input 1

Table 7: Interrupt Mask Group (Continued)

Address	Register Name	Bits	R/W	Function
0001240	INT_ENABLESET	0	S	Enable bit set for VMECC errors
		1	S	Enable bit set for VME IRQ level 1
		2	S	Enable bit set for VME IRQ level 2
		3	S	Enable bit set for VME IRQ level 3
		4	S	Enable bit set for VME IRQ level 4
		5	S	Enable bit set for VME IRQ level 5
		6	S	Enable bit set for VME IRQ level 6
		7	S	Enable bit set for VME IRQ level 7
		8	S	Enable bit set for DMA engine
		9	S	Enable bit set for general purpose input 0
		10	S	Enable bit set for general purpose input 1
		11	S	General purpose output bit 0
		12	S	General purpose output bit 1
0001220	INT_ENABLECLR	0	C	Enable bit clear for VMECC errors
		1	C	Enable bit clear for VME IRQ level 1
		2	C	Enable bit clear for VME IRQ level 2
		3	C	Enable bit clear for VME IRQ level 3
		4	C	Enable bit clear for VME IRQ level 4
		5	C	Enable bit clear for VME IRQ level 5
		6	C	Enable bit clear for VME IRQ level 6
		7	C	Enable bit clear for VME IRQ level 7
		8	C	Enable bit clear for DMA engine
		9	C	Enable bit clear for general purpose input 0
		10	C	Enable bit clear for general purpose input 1
		11	C	General purpose output bit 0
		12	C	General purpose output bit 1

2.5.6 PIO Mapping and PIO Timer

This group is distinguished from the configuration group by the possibility that it might be written after initialization time. As described in the PIO Mapping section, there are 15 locations in a PIO mapping RAM. Each location contains six AM bits and nine address bits to extend the address to 32 bits. The PIO mapping allows access to 15 times 8Mb of VME address space at one time. Usually, this will be enough even if the mapping is allocated statically. However, if more address space is needed, software could, with locks, allow one or more of the map locations to be changed during system operation.

Also in this group is the PIO delay register. Properly designed VME boards should not require this register since a board should factor any required delays between accesses into its speed of handshakes. However, boards exist that require a certain amount of delay between accesses. Because of the multiple buses and fifos between the R4000s and the VME bus, it is impossible to program a delay directly from the R4000s, so this register is needed. A write with a given value to this location causes delay of that many ticks before another PIO operation of any type can proceed. The unit of time is 16 of the VMECC's clock periods; if the VMECC is running at 50MHz, this is 320ns. The value written is an 8 bit value, so this allows delays of at least 80 microseconds.

Table 8: PIO Mapping and Timer Group

Address	Register Name	Bits	R/W	Function
0001180	PIOTIMER	7:0	W	Delay all PIOs for number of ticks in data field
0001380	PIOMAP0	15:0	R/W	initialize to all zeros; used for A16 upper address bits on bus (really shouldn't be used by A16 slaves but zero it anyway)
0001388	PIOMAP1	8:0	R/W	extend Big Window PIO addresses to 32 bits with these bits in A31-A23 for 00800000-00FFFFFF
		9	R/W	reserved
		15:10	R/W	AM bits for this access
0001390	PIOMAP2	15:0 ¹	R/W	PIO mapping bits for 01000000 - 017FFFFFFF
0001398	PIOMAP3	15:0	R/W	PIO mapping bits for 01800000 - 01FFFFFFF
00013A0	PIOMAP4	15:0	R/W	PIO mapping bits for 02000000 - 027FFFFFFF
00013A8	PIOMAP5	15:0	R/W	PIO mapping bits for 02800000 - 02FFFFFFF
00013B0	PIOMAP6	15:0	R/W	PIO mapping bits for 03000000 - 037FFFFFFF
00013B8	PIOMAP7	15:0	R/W	PIO mapping bits for 03800000 - 03FFFFFFF
00013C0	PIOMAP8	15:0	R/W	PIO mapping bits for 04000000 - 047FFFFFFF
00013C8	PIOMAP9	15:0	R/W	PIO mapping bits for 04800000 - 04FFFFFFF
00013D0	PIOMAP10	15:0	R/W	PIO mapping bits for 05000000 - 057FFFFFFF
00013D8	PIOMAP11	15:0	R/W	PIO mapping bits for 05800000 - 05FFFFFFF
00013E0	PIOMAP12	15:0	R/W	PIO mapping bits for 06000000 - 067FFFFFFF
00013E8	PIOMAP13	15:0	R/W	PIO mapping bits for 06800000 - 06FFFFFFF
00013F0	PIOMAP14	15:0	R/W	PIO mapping bits for 07000000 - 077FFFFFFF
00013F8	PIOMAP15	15:0	R/W	PIO mapping bits for 07800000 - 07FFFFFFF

1. PIOMAP2 - PIOMAP15 have the same bit assignments detailed for PIOMAP1

2.6 Diagnostics Features

By setting the PIO map and slave enable bits appropriately, PIO loop-backs going out to the VME bus itself are possible in both directions involving PIOs and DMA. The interrupt request bit register is writable so that EBUS interrupt vectors can be artificially scheduled to test the interrupt vector values and mechanism. The DMA engine cannot be used for loop-backs.

2.7 Error Handling

The VMECC has a register to capture FCI error conditions and VME buserror occurrence. It also has two registers to capture the VME address, AM bits, DS0/1, LW, etc. These registers capture the first errors on each side until rearmed.

The basic strategy for errors is that errors that are bad FCI data parity, or errors originating on the VME bus (timeouts) cause an interrupt, while FCI command parity errors or FCI protocol timeouts (no handshake or data after a request) cause a request to the F-chip to reset the FCI bus. The latter operation in turn causes the F-chip to cause an interrupt. DMA read data with bad parity is passed through to the VME bus with the VME Bus Error asserted to inform the controller; it presumably will interrupt the system. PIO operations with bad data parity on address or data will not be put onto the VME bus; they will cause an interrupt and any such bad PIO Reads will be allowed to time out way back at the R4000.

2.8 Bi-Endian Support

The DMA input and output fifos have byte swappers between them and the VME bus. Finding and delivering data within the 64 bit FCI double words for PIOs is endian sensitive. The address of a VME PIO operation is copied to the VME bus; where the data is found or delivered on the FCI bus will depend on the endian mode. Basically, DMA data is byte-swapped and PIO operations are not logically swapped.

2.9 Device ID

The VMECC returns an eight bit device ID in response to a FCI reset command. This ID is divided into four bit major and minor fields.

Table 9: Device ID

Major ID (Bits 7:4)	Minor ID (Bits 3:0)	Description
0x1	0x1	VMECC with VME bus attached
	0x2	VMECC with HIPPI attached

CHAPTER 3**Hardware Specification**

3.1 Block diagram

The VMECC block diagram shows the major sections of the chip and major interconnects. The block title “local registers” actually includes many of the other blocks such as the A64 Upper Address register, etc.

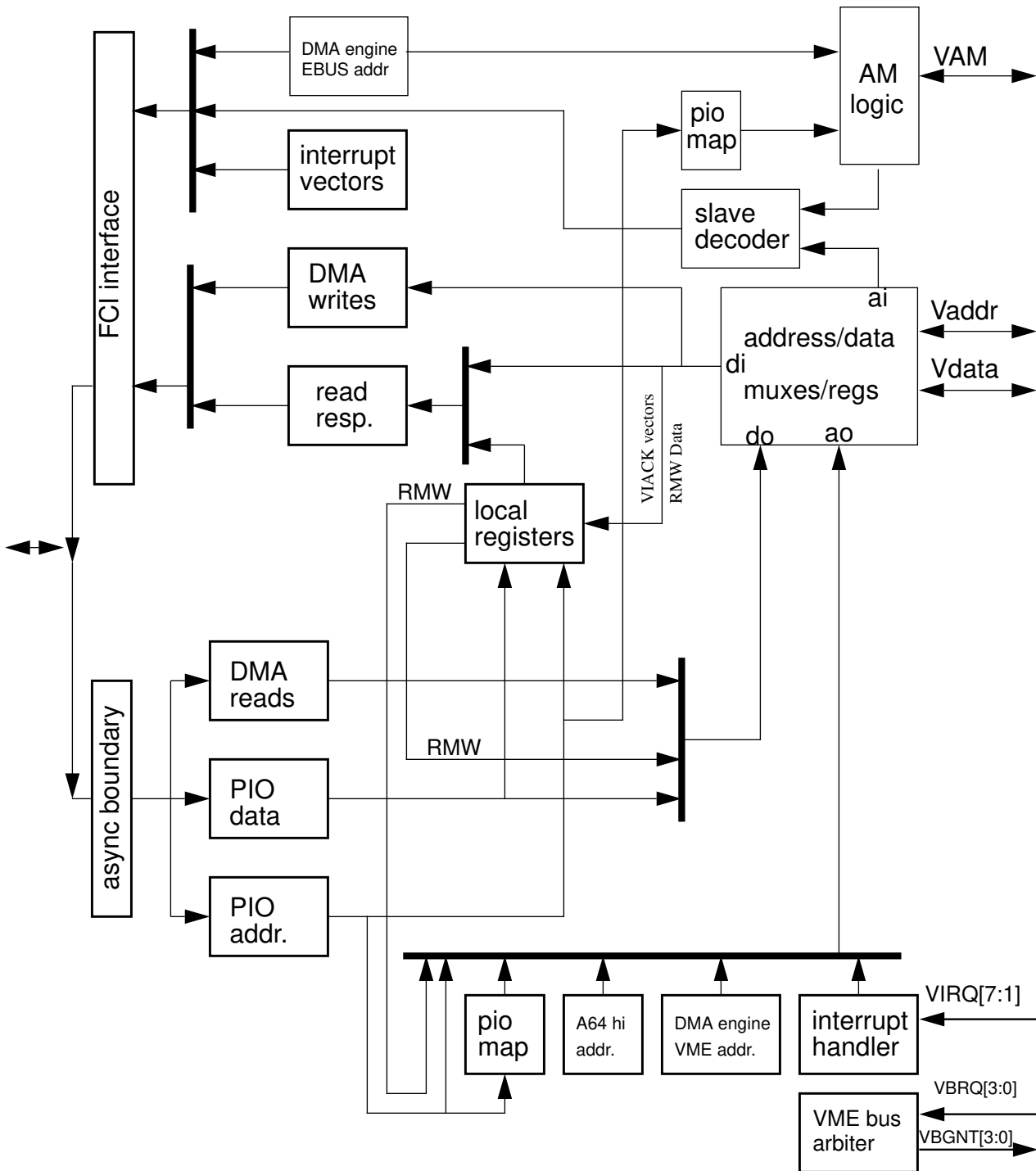

Figure 2 VMECC Block Diagram

3.1.1 FCI Input Block

3.1.1.1 Input Synchronizer

3.1.1.2 PIO Address Fifo

3.1.1.3 PIO Data Fifo

3.1.2 FCI Output Block

3.1.2.1 Interrupt Vectors

3.1.2.2 DMA Write Fifo

3.1.2.3 Read Responses

3.1.3 Local Registers

3.1.4 VME Bus Multiplexers and Registers

3.1.5 Slave Decoder

3.1.6 VME Arbiter

3.1.7 Interrupt Handler

3.2 FCI Interface

The FCI interface protocol is described in the FCI Specification.

3.3 VME Interface

The VME protocol is described in the VMEbus Specification C.1 and D.

CHAPTER 4**Testability**

4.1 Diagnostics

The VMECC supports VME PIO loopbacks, where a PIO operation can cause a DMA operation to system memory. RMW operation can also do loopback tests. The INT_REQUESTSM register greatly aids in checking the interrupt system and the LOOPBACKTRIG location helps to exercise the FCI AuxCmd bus more easily.

4.2 Scan

The VMECC has JTAG boundary scan and (almost) all internal register bits are scannable.

CHAPTER 5 Implementation

5.1 Technology

LSI Logic 200K technology, 182K gate die.

5.2 Gate Count

77K used gates

5.3 Package Type

299 PPGA

5.4 Pin List

The following three tables summarize the pins of the VMECC.

5.4.1 FCI Side

Table 10: FCI Side Pins

Pins	Name	Used For
32	FCIDB_L	data
2	FCIDBP_L	parity on data pins FCIDB
1	FCIMCLK_H	master clock; sample clock for data leaving VMECC
1	FCIMCLK_L	master clock; sample clock for data leaving VMECC
1	FCIMOKTD	signal from VMECC to F-chip that it's "OK to drive" data bus
2	FCIMCMD_L	command bits from VMECC
8	FCIMAUXCMD_L	byte selects, read resp. #, interrupt or address from VMECC
1	FCIMCMDP_L	parity bit on master (VMECC) all command pins
1	FCIMVREF	NTL voltage reference for the VMECC outputs
1	FCISCLK_H	slave clock; sample clock for data leaving F-chip
1	FCISCLK_L	slave clock; sample clock for data leaving F-chip
1	FCISOE	signal that F-chip is driving FCIDB data bus
2	FCISCMD_L	command bits from F-chip
1	FCISCMDP_L	parity bit on slave (F-chip) all command pins
1	FCISVREF	NTL voltage reference for F chip outputs
1	FCISBEND_L	when true, system is big-endian
1	FCIMDOE_L	auxiliary wire to control actual external drivers
58	Total Pins	

5.4.2 VME Side

Table 11: VME Side Pins

Bits	Signal Name	Used For
32	VDATA[31:0]	data bits D31-D0 and A64 address bits A63-A32
1	VDATA_OUT_EN	enable for F623 to drive from VMECC to VMEbus
1	VDATA_IN_EN	enable for F623 to drive from VMEbus to VMECC
31	VADDR[31:1]	address bits A31-A1 and D64 data bits D63-D33
1	VLWORD	long word and D64 data bit D32 (part of vaddr group)
1	VADDR_OUT_EN	enable for F623 to drive from VMECC to VMEbus
1	VADDR_IN_EN	enable for F623 to drive from VMEbus to VMECC
1	VWRITE_OUT_L	direction of transfer driven when VMECC is master
1	VDS0_OUT_L	lower data strobe driven when VMECC is master
1	VDS1_OUT_L	upper data strobe driven when VMECC is master
1	VAS_OUT_L	address strobe driven when VMECC is master
6	VAM[5:0]	address modifier bits
1	VIACK_L	the bussed IACK signal that invalidates A31-A4 and AM5-0; driven onto bus by same F623 part as VAM
1	VAM_OUT_EN_L	enable for F623 to drive from VMECC to VMEbus (also output enable for F244 to drive AS, DS1, DS0, WRITE)
1	VAM_IN_EN	enable for F623 to drive from VMEbus to VMECC
1	VWRITE_IN	direction of transfer on VMEbus
1	VDS0_IN	lower data strobe
1	VDS1_IN	upper data strobe
1	VDSX	the OR of DS1 and DS0
1	VDSX_D20	VDSX delayed 20ns
1	VAS_IN	address strobe
1	VBERR_IN	VME bus error input

Table 11: VME Side Pins (Continued)

Bits	Signal Name	Used For
1	VBBSY_IN	VME bus busy input
1	VDTACK_IN	data acknowledge
1	VBERR_OUT	O.C. VME bus error when VMECC is slave or by bus timer
1	VBBSY_OUT	O.C. VME bus busy output when VMECC is master
1	VMYREQ	O.C. VBR3&2 driven when an internal master wants service
1	VCLR_OUT	VME bus clear driven by internal arbiter
1	VME_RESET_OUT_L	reset out
1	VME_RESET_IN_L	reset in; probably from a PON low voltage detector chip
7	VIRQ[7:1]	VME interrupt request line inputs
4	VBRQ_IN[3:0]	VME bus request line inputs
4	VGNT_OUT[3:0]	VME bus grant outputs from internal arbiter
2	AUX_INTR[1:0]	auxiliary interrupt pins
2	AUX_OUT[1:0]	auxiliary output pins
1	WT_CLK_A	clock for A-side input registers
1	WT_CLK_B	clock for B-side input registers
1	WT_CLK_A_LOOP	WT_CLK_A looped through chip to tell the external handshake logic that the chip has seen it
1	WT_CLK_B_LOOP	WT_CLK_B looped through chip to tell the external handshake logic that the chip has seen it
1	SLAVEON	allows external slave logic to handshake; signal that VMECC has recognized and prepared for a slave response
1	SLAVE_WRITE	the direction the VMECC is expecting for a slave response; helps to detect RMW slave cycles
1	CURRENT_CYCLE	output of external asynchronous state machine -- this is the same VME cycle that the VMECC has recognized
1	D64_SLAVE_READ	indicates that the VMEA buffers should drive the VME address bus as well as the data bus during slave reads

Table 11: VME Side Pins (Continued)

Bits	Signal Name	Used For
1	FLAG_A	one bit of the two bit grey counter; how far the external asynchronous logic has progressed
1	FLAG_B	one bit of the two bit grey counter; how far the external asynchronous logic has progressed
1	CLR_GREY_CNTR	clears the external two bit grey counter FLAG_A/FLAG_B
1	ACK_A	one of two signals to external handshake logic telling it how far it may proceed
1	ACK_B	one of two signals to external handshake logic telling it how far it may proceed
1	DTACK_OUT	allows a handshake to acknowledge first A64/D64 cycle
1	HIPPI_MODE_L	shortens handshakes and alters prefetch strategy
1	VCLOCK_OUT	internal clock brought out for synchrfonous interface (HIPPI board)
131	Total Pins	

5.4.3 Pin Count Summary

The VMECC fits in a 299 pin PGA.

Table 12: Total Pins

Pins	Name	Used For
1	clock_in	clock input
7	PLL	PLL control pins for FCI input clock
6	SCAN / NAND	JTAG pins and LSI NAND-tree
29	FCI-BUS/2	grounds for NTL pins
4	VSS-VME	grounds for TTL side pins
8	VCC2	5V for TTL side pins
6	VSS	core grounds
6	VCC	core VCC
58	FCI-side	FCI bus signals
131	VME-side	VME pins
273	Total Pins	

Table 13: Chip Pinout by Name

name	pin		direction
ACK_A	C	10	OUT
ACK_B	A	8	OUT
AUX_INTR_0_	A	15	IN
AUX_INTR_1_	E	12	IN
AUX_OUT_0_	B	14	OUT
AUX_OUT_1_	D	12	OUT
CLOCK2X	U	12	IN
CLOCK_RESET_L	T	12	IN
CLR_GREY_CNTR	C	11	OUT
CURRENT_CYCLE	V	12	IN
D64_SLAVE_READ	B	13	OUT
DTACK_OUT	E	11	OUT
FCIDBP_L_0_	J	17	BIDIR
FCIDBP_L_1_	U	15	BIDIR
FCIDB_L_0_	B	15	BIDIR
FCIDB_L_10_	D	19	BIDIR
FCIDB_L_11_	E	18	BIDIR
FCIDB_L_12_	D	20	BIDIR
FCIDB_L_13_	E	19	BIDIR
FCIDB_L_14_	F	18	BIDIR
FCIDB_L_15_	E	20	BIDIR
FCIDB_L_16_	P	18	BIDIR
FCIDB_L_17_	R	19	BIDIR
FCIDB_L_18_	J	18	BIDIR
FCIDB_L_19_	R	18	BIDIR

Table 13: Chip Pinout by Name

name	pin		direction
FCIDB_L_1_	A	16	BIDIR
FCIDB_L_20_	K	16	BIDIR
FCIDB_L_21_	K	18	BIDIR
FCIDB_L_22_	D	16	BIDIR
FCIDB_L_23_	U	19	BIDIR
FCIDB_L_24_	V	17	BIDIR
FCIDB_L_25_	U	16	BIDIR
FCIDB_L_26_	W	17	BIDIR
FCIDB_L_27_	V	16	BIDIR
FCIDB_L_28_	W	16	BIDIR
FCIDB_L_29_	X	16	BIDIR
FCIDB_L_2_	C	15	BIDIR
FCIDB_L_30_	V	15	BIDIR
FCIDB_L_31_	W	15	BIDIR
FCIDB_L_3_	B	16	BIDIR
FCIDB_L_4_	A	17	BIDIR
FCIDB_L_5_	C	16	BIDIR
FCIDB_L_6_	B	17	BIDIR
FCIDB_L_7_	T	18	BIDIR
FCIDB_L_8_	D	18	BIDIR
FCIDB_L_9_	E	17	BIDIR
FCIMAUXCMD_L_0_	T	17	OUT
FCIMAUXCMD_L_1_	U	18	OUT
FCIMAUXCMD_L_2_	V	19	OUT
FCIMAUXCMD_L_3_	U	17	OUT

Table 13: Chip Pinout by Name

name	pin		direction
FCIMAUXCMD_L_4_	W	19	OUT
FCIMAUXCMD_L_5_	T	20	OUT
FCIMAUXCMD_L_6_	U	20	OUT
FCIMAUXCMD_L_7_	T	19	OUT
FCIMCLK_H	K	17	OUT
FCIMCLK_L	K	19	OUT
FCIMCMDP_L	M	17	OUT
FCIMCMD_L_0_	M	16	OUT
FCIMCMD_L_1_	N	17	OUT
FCIMDOE_L	N	16	OUT
FCIMOKTD	M	18	OUT
FCISBEND_L	L	19	IN
FCISCLK_H	E	16	IN
FCISCLK_L	F	16	IN
FCISCMDP_L	L	16	IN
FCISCMD_L_0_	M	19	IN
FCISCMD_L_1_	L	18	IN
FCISOE	N	20	IN
FCISVREF	L	17	IN
FLAG_A	C	12	IN
FLAG_B	A	14	IN
HIPPI_MODE_L	C	13	IN
IDDTEST_L	G	17	IN
JTAG_TCK	H	16	IN
JTAG_TDI	G	18	IN

Table 13: Chip Pinout by Name

name	pin		direction
JTAG_TDO	F	20	OUT
JTAG_TMS	H	17	IN
LP1	E	15	OUT
LP2	E	14	IN
PLLBYPASS_L	C	18	IN
PLLTESTOUT	C	17	OUT
PLLVDD	B	19	IN
PLLVSS	D	15	IN
PLLVSSAGND	B	18	OUT
RAMTEST_L	U	13	IN
SCLK2X_OUT	T	13	IN
SCLR_L	V	14	IN
SLAVEON	B	12	OUT
SLAVE_WRITE	D	11	OUT
TESTOUT	J	16	OUT
TEST_L	V	10	IN
VADDR_10_	K	3	BIDIR
VADDR_11_	J	3	BIDIR
VADDR_12_	J	5	BIDIR
VADDR_13_	J	2	BIDIR
VADDR_14_	K	2	BIDIR
VADDR_15_	L	2	BIDIR
VADDR_16_	M	2	BIDIR
VADDR_17_	N	2	BIDIR
VADDR_18_	P	1	BIDIR

Table 13: Chip Pinout by Name

name	pin		direction
VADDR_19_	N	3	BIDIR
VADDR_1_	L	5	BIDIR
VADDR_20_	P	3	BIDIR
VADDR_21_	R	2	BIDIR
VADDR_22_	P	4	BIDIR
VADDR_23_	T	1	BIDIR
VADDR_24_	L	4	BIDIR
VADDR_25_	H	3	BIDIR
VADDR_26_	H	4	BIDIR
VADDR_27_	H	5	BIDIR
VADDR_28_	H	1	BIDIR
VADDR_29_	G	1	BIDIR
VADDR_2_	L	3	BIDIR
VADDR_30_	G	2	BIDIR
VADDR_31_	G	3	BIDIR
VADDR_3_	M	3	BIDIR
VADDR_4_	M	5	BIDIR
VADDR_5_	R	1	BIDIR
VADDR_6_	N	4	BIDIR
VADDR_7_	N	5	BIDIR
VADDR_8_	K	4	BIDIR
VADDR_9_	K	5	BIDIR
VADDR_IN_EN	C	8	OUT
VADDR_OUT_EN	E	9	OUT
VAM_0_	W	3	BIDIR

Table 13: Chip Pinout by Name

name	pin		direction
VAM_1_	V	4	BIDIR
VAM_2_	U	5	BIDIR
VAM_3_	W	4	BIDIR
VAM_4_	X	4	BIDIR
VAM_5_	W	5	BIDIR
VAM_IN_EN	W	11	OUT
VAM_OUT_EN_L	U	10	OUT
VAS_IN	C	9	IN
VAS_OUT_L	A	7	OUT
VBBSY_IN	E	8	IN
VBBSY_OUT	D	8	OUT
VBERR_IN	C	7	IN
VBERR_OUT	B	7	OUT
VBRQ_IN_0_	T	8	IN
VBRQ_IN_1_	U	8	IN
VBRQ_IN_2_	V	8	IN
VBRQ_IN_3_	T	9	IN
VCLOCK_OUT	A	6	OUT
VCLR_OUT	D	7	OUT
VDATA_0_	U	7	BIDIR
VDATA_10_	U	3	BIDIR
VDATA_11_	T	4	BIDIR
VDATA_12_	T	3	BIDIR
VDATA_13_	U	1	BIDIR
VDATA_14_	T	2	BIDIR

Table 13: Chip Pinout by Name

name	pin		direction
VDATA_15_	R	3	BIDIR
VDATA_16_	G	4	BIDIR
VDATA_17_	G	5	BIDIR
VDATA_18_	F	4	BIDIR
VDATA_19_	E	4	BIDIR
VDATA_1_	T	7	BIDIR
VDATA_20_	E	5	BIDIR
VDATA_21_	E	6	BIDIR
VDATA_22_	D	6	BIDIR
VDATA_23_	E	7	BIDIR
VDATA_24_	F	1	BIDIR
VDATA_25_	F	2	BIDIR
VDATA_26_	F	3	BIDIR
VDATA_27_	E	1	BIDIR
VDATA_28_	E	3	BIDIR
VDATA_29_	D	2	BIDIR
VDATA_2_	U	6	BIDIR
VDATA_30_	D	3	BIDIR
VDATA_31_	C	2	BIDIR
VDATA_3_	T	6	BIDIR
VDATA_4_	T	5	BIDIR
VDATA_5_	R	5	BIDIR
VDATA_6_	R	4	BIDIR
VDATA_7_	P	5	BIDIR
VDATA_8_	W	2	BIDIR

Table 13: Chip Pinout by Name

name	pin		direction
VDATA_9_	V	2	BIDIR
VDATA_IN_EN	B	6	OUT
VDATA_OUT_EN	C	6	OUT
VDD	B	4	IN
VDD	B	8	IN
VDD	E	2	IN
VDD	H	2	IN
VDD	M	4	IN
VDD	U	2	IN
VDD	U	9	IN
VDD	V	5	IN
VDS0_IN	W	8	IN
VDS0_OUT_L	A	5	OUT
VDS1_IN	V	9	IN
VDS1_OUT_L	B	5	OUT
VDSX	W	9	IN
VDSX_D20	W	10	IN
VDTACK_IN	B	11	IN
VGNT_OUT_0_	W	6	OUT
VGNT_OUT_1_	V	7	OUT
VGNT_OUT_2_	X	6	OUT
VGNT_OUT_3_	W	7	OUT
VIACK_L	X	5	BIDIR
VIRQ_1_	W	12	IN
VIRQ_2_	U	11	IN

Table 13: Chip Pinout by Name

name	pin		direction
VIRQ_3_	X	13	IN
VIRQ_4_	T	11	IN
VIRQ_5_	W	13	IN
VIRQ_6_	V	11	IN
VIRQ_7_	V	13	IN
VLWORD	V	6	BIDIR
VME_RESET_IN_L	C	4	IN
VME_RESET_OUT_L	C	5	OUT
VMYREQ	D	5	OUT
VSS	C	3	IN
VSS	C	19	IN
VSS	D	9	IN
VSS	D	14	IN
VSS	E	13	IN
VSS	F	5	IN
VSS	F	17	IN
VSS	F	19	IN
VSS	G	16	IN
VSS	G	19	IN
VSS	H	18	IN
VSS	H	19	IN
VSS	J	4	IN
VSS	J	19	IN
VSS	N	18	IN
VSS	N	19	IN

Table 13: Chip Pinout by Name

name	pin		direction
VSS	P	16	IN
VSS	P	17	IN
VSS	P	20	IN
VSS	R	16	IN
VSS	R	17	IN
VSS	T	14	IN
VSS	T	16	IN
VSS	U	14	IN
VSS	V	3	IN
VSS	W	14	IN
VSS	W	18	IN
VSS	X	7	IN
VSS	X	14	IN
VSS2	G	20	IN
VSS2	P	2	IN
VSS2	P	19	IN
VSS2	R	20	IN
VWRITE_IN	T	10	IN
VWRITE_OUT_L	B	3	OUT
WT_CLK_A	E	10	IN
WT_CLK_A_LOOP	D	10	OUT
WT_CLK_B	B	9	IN
WT_CLK_B_LOOP	B	10	OUT

Table 14: Chip Pinout by Pin Number

name	pin		direction
VDS0_OUT_L	A	5	OUT
VCLOCK_OUT	A	6	OUT
VAS_OUT_L	A	7	OUT
ACK_B	A	8	OUT
FLAG_B	A	14	IN
AUX_INTR_0_	A	15	IN
FCIDB_L_1_	A	16	BIDIR
FCIDB_L_4_	A	17	BIDIR
VWRITE_OUT_L	B	3	OUT
VDD	B	4	IN
VDS1_OUT_L	B	5	OUT
VDATA_IN_EN	B	6	OUT
VBERR_OUT	B	7	OUT
VDD	B	8	IN
WT_CLK_B	B	9	IN
WT_CLK_B_LOOP	B	10	OUT
VDTACK_IN	B	11	IN
SLAVEON	B	12	OUT
D64_SLAVE_READ	B	13	OUT
AUX_OUT_0_	B	14	OUT
FCIDB_L_0_	B	15	BIDIR
FCIDB_L_3_	B	16	BIDIR
FCIDB_L_6_	B	17	BIDIR
PLLVSSAGND	B	18	OUT

Table 14: Chip Pinout by Pin Number

name	pin		direction
PLLVDDB	B	19	IN
VDATA_31_	C	2	BIDIR
VSS	C	3	IN
VME_RESET_IN_L	C	4	IN
VME_RESET_OUT_L	C	5	OUT
VDATA_OUT_EN	C	6	OUT
VBERR_IN	C	7	IN
VADDR_IN_EN	C	8	OUT
VAS_IN	C	9	IN
ACK_A	C	10	OUT
CLR_GREY_CNTR	C	11	OUT
FLAG_A	C	12	IN
HIPPI_MODE_L	C	13	IN
FCIDB_L_2_	C	15	BIDIR
FCIDB_L_5_	C	16	BIDIR
PLLTESTOUT	C	17	OUT
PLLBYPASS_L	C	18	IN
VSS	C	19	IN
VDATA_29_	D	2	BIDIR
VDATA_30_	D	3	BIDIR
VMYREQ	D	5	OUT
VDATA_22_	D	6	BIDIR
VCLR_OUT	D	7	OUT
VBBSY_OUT	D	8	OUT
VSS	D	9	IN

Table 14: Chip Pinout by Pin Number

name	pin		direction
WT_CLK_A_LOOP	D	10	OUT
SLAVE_WRITE	D	11	OUT
AUX_OUT_1_	D	12	OUT
VSS	D	14	IN
PLLVSS	D	15	IN
FCIDB_L_22_	D	16	BIDIR
FCIDB_L_8_	D	18	BIDIR
FCIDB_L_10_	D	19	BIDIR
FCIDB_L_12_	D	20	BIDIR
VDATA_27_	E	1	BIDIR
VDD	E	2	IN
VDATA_28_	E	3	BIDIR
VDATA_19_	E	4	BIDIR
VDATA_20_	E	5	BIDIR
VDATA_21_	E	6	BIDIR
VDATA_23_	E	7	BIDIR
VBBSY_IN	E	8	IN
VADDR_OUT_EN	E	9	OUT
WT_CLK_A	E	10	IN
DTACK_OUT	E	11	OUT
AUX_INTR_1_	E	12	IN
VSS	E	13	IN
LP2	E	14	IN
LP1	E	15	OUT
FCISCLK_H	E	16	IN

Table 14: Chip Pinout by Pin Number

name	pin		direction
FCIDB_L_9_	E	17	BIDIR
FCIDB_L_11_	E	18	BIDIR
FCIDB_L_13_	E	19	BIDIR
FCIDB_L_15_	E	20	BIDIR
VDATA_24_	F	1	BIDIR
VDATA_25_	F	2	BIDIR
VDATA_26_	F	3	BIDIR
VDATA_18_	F	4	BIDIR
VSS	F	5	IN
FCISCLK_L	F	16	IN
VSS	F	17	IN
FCIDB_L_14_	F	18	BIDIR
VSS	F	19	IN
JTAG_TDO	F	20	OUT
VADDR_29_	G	1	BIDIR
VADDR_30_	G	2	BIDIR
VADDR_31_	G	3	BIDIR
VDATA_16_	G	4	BIDIR
VDATA_17_	G	5	BIDIR
VSS	G	16	IN
IDDTEST_L	G	17	IN
JTAG_TDI	G	18	IN
VSS	G	19	IN
VSS2	G	20	IN
VADDR_28_	H	1	BIDIR

Table 14: Chip Pinout by Pin Number

name	pin		direction
VDD	H	2	IN
VADDR_25_	H	3	BIDIR
VADDR_26_	H	4	BIDIR
VADDR_27_	H	5	BIDIR
JTAG_TCK	H	16	IN
JTAG_TMS	H	17	IN
VSS	H	18	IN
VSS	H	19	IN
VADDR_13_	J	2	BIDIR
VADDR_11_	J	3	BIDIR
VSS	J	4	IN
VADDR_12_	J	5	BIDIR
TESTOUT	J	16	OUT
FCIDBP_L_0_	J	17	BIDIR
FCIDB_L_18_	J	18	BIDIR
VSS	J	19	IN
VADDR_14_	K	2	BIDIR
VADDR_10_	K	3	BIDIR
VADDR_8_	K	4	BIDIR
VADDR_9_	K	5	BIDIR
FCIDB_L_20_	K	16	BIDIR
FCIMCLK_H	K	17	OUT
FCIDB_L_21_	K	18	BIDIR
FCIMCLK_L	K	19	OUT
VADDR_15_	L	2	BIDIR

Table 14: Chip Pinout by Pin Number

name	pin		direction
VADDR_2_	L	3	BIDIR
VADDR_24_	L	4	BIDIR
VADDR_1_	L	5	BIDIR
FCISCMDP_L	L	16	IN
FCISVREF	L	17	IN
FCISCMD_L_1_	L	18	IN
FCISBEND_L	L	19	IN
VADDR_16_	M	2	BIDIR
VADDR_3_	M	3	BIDIR
VDD	M	4	IN
VADDR_4_	M	5	BIDIR
FCIMCMD_L_0_	M	16	OUT
FCIMCMDP_L	M	17	OUT
FCIMOKTD	M	18	OUT
FCISCMD_L_0_	M	19	IN
VADDR_17_	N	2	BIDIR
VADDR_19_	N	3	BIDIR
VADDR_6_	N	4	BIDIR
VADDR_7_	N	5	BIDIR
FCIMDOE_L	N	16	OUT
FCIMCMD_L_1_	N	17	OUT
VSS	N	18	IN
VSS	N	19	IN
FCISOE	N	20	IN
VADDR_18_	P	1	BIDIR

Table 14: Chip Pinout by Pin Number

name	pin		direction
VSS2	P	2	IN
VADDR_20_	P	3	BIDIR
VADDR_22_	P	4	BIDIR
VDATA_7_	P	5	BIDIR
VSS	P	16	IN
VSS	P	17	IN
FCIDB_L_16_	P	18	BIDIR
VSS2	P	19	IN
VSS	P	20	IN
VADDR_5_	R	1	BIDIR
VADDR_21_	R	2	BIDIR
VDATA_15_	R	3	BIDIR
VDATA_6_	R	4	BIDIR
VDATA_5_	R	5	BIDIR
VSS	R	16	IN
VSS	R	17	IN
FCIDB_L_19_	R	18	BIDIR
FCIDB_L_17_	R	19	BIDIR
VSS2	R	20	IN
VADDR_23_	T	1	BIDIR
VDATA_14_	T	2	BIDIR
VDATA_12_	T	3	BIDIR
VDATA_11_	T	4	BIDIR
VDATA_4_	T	5	BIDIR
VDATA_3_	T	6	BIDIR

Table 14: Chip Pinout by Pin Number

name	pin		direction
VDATA_1_	T	7	BIDIR
VBRQ_IN_0_	T	8	IN
VBRQ_IN_3_	T	9	IN
VWRITE_IN	T	10	IN
VIRQ_4_	T	11	IN
CLOCK_RESET_L	T	12	IN
SCLK2X_OUT	T	13	IN
VSS	T	14	IN
VSS	T	16	IN
FCIMAUXCMD_L_0_	T	17	OUT
FCIDB_L_7_	T	18	BIDIR
FCIMAUXCMD_L_7_	T	19	OUT
FCIMAUXCMD_L_5_	T	20	OUT
VDATA_13_	U	1	BIDIR
VDD	U	2	IN
VDATA_10_	U	3	BIDIR
VAM_2_	U	5	BIDIR
VDATA_2_	U	6	BIDIR
VDATA_0_	U	7	BIDIR
VBRQ_IN_1_	U	8	IN
VDD	U	9	IN
VAM_OUT_EN_L	U	10	OUT
VIRQ_2_	U	11	IN
CLOCK2X	U	12	IN
RAMTEST_L	U	13	IN

Table 14: Chip Pinout by Pin Number

name	pin		direction
VSS	U	14	IN
FCIDBP_L_1_	U	15	BIDIR
FCIDB_L_25_	U	16	BIDIR
FCIMAUXCMD_L_3_	U	17	OUT
FCIMAUXCMD_L_1_	U	18	OUT
FCIDB_L_23_	U	19	BIDIR
FCIMAUXCMD_L_6_	U	20	OUT
VDATA_9_	V	2	BIDIR
VSS	V	3	IN
VAM_1_	V	4	BIDIR
VDD	V	5	IN
VLWORD	V	6	BIDIR
VGNT_OUT_1_	V	7	OUT
VBRQ_IN_2_	V	8	IN
VDS1_IN	V	9	IN
TEST_L	V	10	IN
VIRQ_6_	V	11	IN
CURRENT_CYCLE	V	12	IN
VIRQ_7_	V	13	IN
SCLR_L	V	14	IN
FCIDB_L_30_	V	15	BIDIR
FCIDB_L_27_	V	16	BIDIR
FCIDB_L_24_	V	17	BIDIR
FCIMAUXCMD_L_2_	V	19	OUT
VDATA_8_	W	2	BIDIR

Table 14: Chip Pinout by Pin Number

name	pin		direction
VAM_0_	W	3	BIDIR
VAM_3_	W	4	BIDIR
VAM_5_	W	5	BIDIR
VGNT_OUT_0_	W	6	OUT
VGNT_OUT_3_	W	7	OUT
VDS0_IN	W	8	IN
VDSX	W	9	IN
VDSX_D20	W	10	IN
VAM_IN_EN	W	11	OUT
VIRQ_1_	W	12	IN
VIRQ_5_	W	13	IN
VSS	W	14	IN
FCIDB_L_31_	W	15	BIDIR
FCIDB_L_28_	W	16	BIDIR
FCIDB_L_26_	W	17	BIDIR
VSS	W	18	IN
FCIMAUXCMD_L_4_	W	19	OUT
VAM_4_	X	4	BIDIR
VIACK_L	X	5	BIDIR
VGNT_OUT_2_	X	6	OUT
VSS	X	7	IN
VIRQ_3_	X	13	IN
VSS	X	14	IN
FCIDB_L_29_	X	16	BIDIR

CHAPTER 6

External Buffer Parts

In order to drive the 100 plus pins of a VME bus with the 48/64 ma required for each line, external buffer parts are used for this design. No registered external parts are used in the data path; only buffers and bidirectional buffers. The VME slave handshake (DTACK) logic and bus driver output enable control is implemented externally with three flip-flops and two asynchronous PALs.

Table 15: External Buffer Parts Required

Count	Part	Used For
4	74F623 ¹	VDATA[31:0]
4	74F623	VADDR[31:1],LWORD
1	74F623	VAM[5:0], VIACK
1	74F125	VDTACK_OUT,AUX_OUT0/1
1/2	74F244	VDS0, VDS1, VAS, VWRITE outputs
1/2	74F244	VCLR_OUT, VRESET_OUT, VME_16MHZ_CLK
1	74F132	VDSX, VWRITE_IN, VDS1, VDS0
5	74F14	various inputs and outputs
1	74F04	buffering for xxxxx_IN output enables
1	74F10	VIACKout logic (all external)
1	74F38	VBERR_OUT, VBSY_OUT, VMYREQ_1, VMYREQ_0
1	DELAY	VDXS_DELAY20, VDSX_DELAY25
1	74F74	AS_OFF detector
1	74F112	two bit grey counter
1	oscillator	16Mhz for VME_CLK
1	oscillator	50Mhz or 100Mhz for internal clock
1	PON I.C.	power-on reset logic
2	PAL	asynchronous logic
28	Total Discrete Parts	

1. A 74x623 part is like a 74x245 part with separate enables for each direction instead of a direction and oe control.